

Let's make sailing safer

At Mac N Hom Marine Equipments (P) Ltd., we are focused on range of products that meet the ever increasing demands of Marine based customers in terms of sophistication and diversification. We have brought to market innovative products, one after another to provide only the highest quality goods and services for your requirements and offer customised solutions and challenging applications quickly and cost effectively.

MAC·N·HOM
MARINE EQUIPMENTS (P) LTD.
 Let's make sailing safer



HYDRAULIC STEERING SYSTEMS

Model : JumboZ-500
 IRS Type Approved



Model Type : Semi-Balanced Actuator
 (IRS Type Approved)
Ram Dia : 40 mm x2 • Stroke : 440 mm
Torque : 714 Kg.m for a Tiller Arm having Radius 300 mm

- Tugs & Bollard Pullers
- Medium Barges
- Heavy duty Purse-seins Trawler
- Fishing Vessels

Tanker Barges - 2 Nos., Cochin Bunkers Pvt. Ltd.



Inspection Barges- 8 Nos.,
 Valeth High Tech Composites, Edayar



Ambulance Boat - 3 Nos.
 Saraswathi Metal Works to Cochin Shipyard Ltd. -



Passenger Boats, SEACON, Vishakhapatnam



20 Ton Bollard Pull Tug,
 Seaglitters Offshore, Mumbai



- ✪ Torque rating up to 700kg.m
- ✪ Tiller Arm turn up to 45 degrees on both sides
- ✪ Used in Catamaran & Single Rudder vessels
- ✪ Used in Cargo Barges/Water Barges & Deep sea Ambulances
- ✪ Heavy Duty Ram Size: 40mm x 2 nos

Package Included

Electro-Hydraulic Package Includes:

- ★ Joystick Control Panel with Audio Visual Alarms
- ★ Hydraulic Power pack & Sensors
- ★ Emergency Manual-Hydraulic Steering Marine Painted Ferruled seamless steel Tubes & Hoses
- ★ Hydraulic Actuator - **JumboZ-500**

Manual-Hydraulic Package Includes:

- ★ Steering Wheel - Wooden/SS
- ★ Helm Pump & Steering Column
- ★ Marine Painted Ferruled Seamless steel Tubes & Hoses
- ★ Hydraulic Actuator-**JumboZ-500**

- 1 Joystick Operated Control Panel with audio visual alarms
- 2 Electro Hydraulic Power Pack with Sensors for Electro Hydraulic Package
- 3 Marine Paint Coated, Ferruled Nut ends Seamless Steel Tubes for Smooth Oil Flow
- 4 Emergency Manual Hydraulic version with Helm Pump, Steering Wheel & Self Priming Unit



2



3



4



MAC·N·HOM MARINE EQUIPMENTS (P) LTD.

57/187-C, 'VRINDAVAN', Chilavannur Road, Kadavanthra, Kochi-682 020, Kerala, India

Mob.: + 91 9072900576, +91 484 2312396, 2319998,

E-mail: info@macnhomsystems.com web site: www.macnhomsystems.com

CIN: U29308KL2018PTC055182



SPECIFICATIONS

- Actuator Ram Diameter : 40 mm. x 2
- Actuator Stroke : 440 mm.
- Force @ 70 Kg / cm² Hydraulic Pressure : 2444 Kgf.
- Torque with 300mm. Tiller Arm upto ±45° turn from Midship.
(Actuator Pin to Rudder Shaft Centre distance : 300mm.) : 714 Kg.m.

MOUNTING ARRANGEMENT OF HYD. ACTUTOR JumboZ-500 - IRS

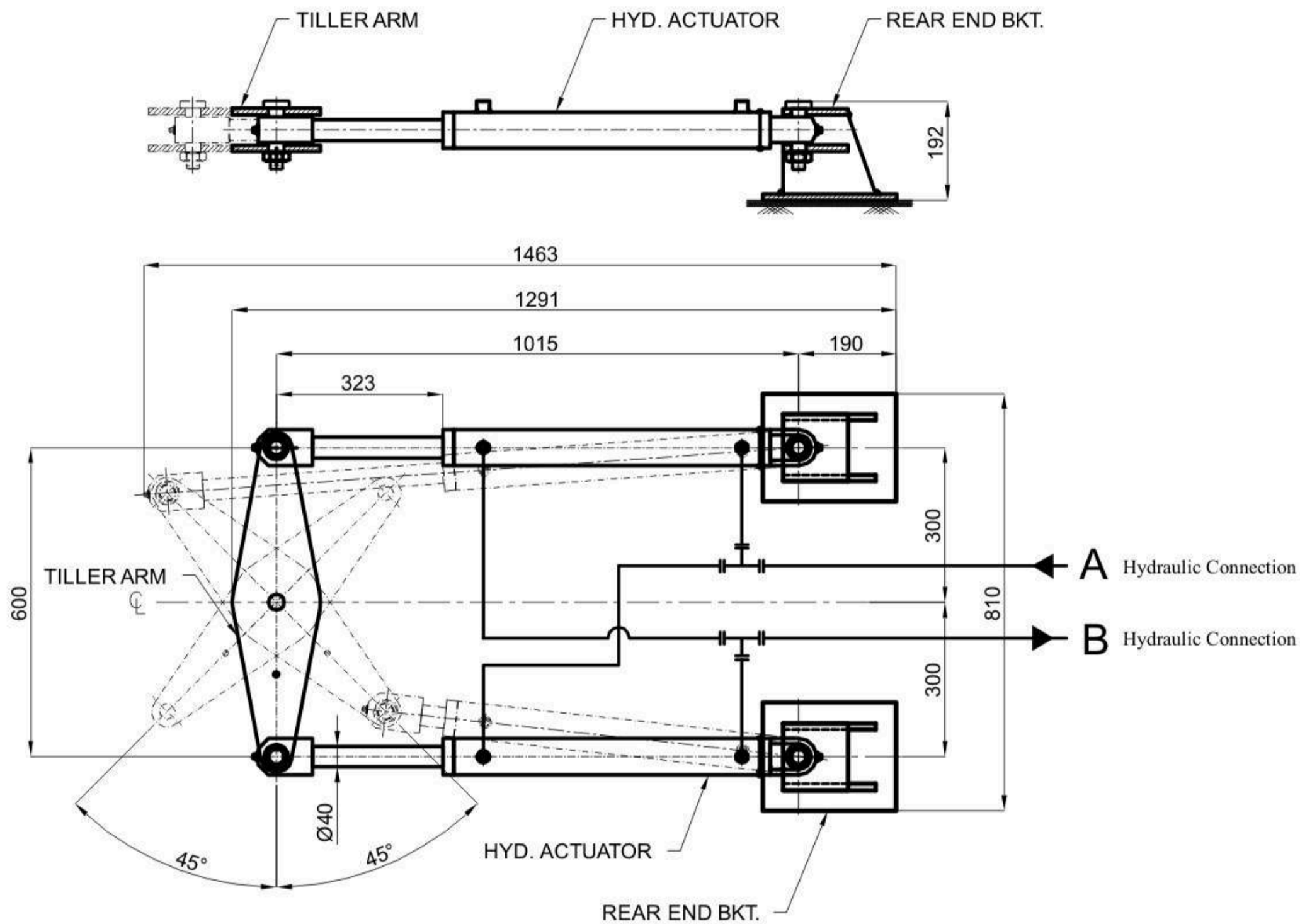

DATA FOR STEERING SELECTION

VESSEL DETAILS		
Length of the Vessel		Meters
Breadth of Vessel		Meters
Draft of the Vessel		Meters
Hull form (Mono / Catamaran)		
No of Engines		Nos
Power of each Engine		HP
Speed of Vessel		Knots
RUDDER DETAILS (See Rudder Dwg.)		
Breadth of Rudder A		Meters
Breadth of Semi-balanced Area B		Meters
Height of Rudder H		Meters
Number of Rudders		Nos
Vessel Regn. Class - No Class / IRS / RINA / DNV / BV		

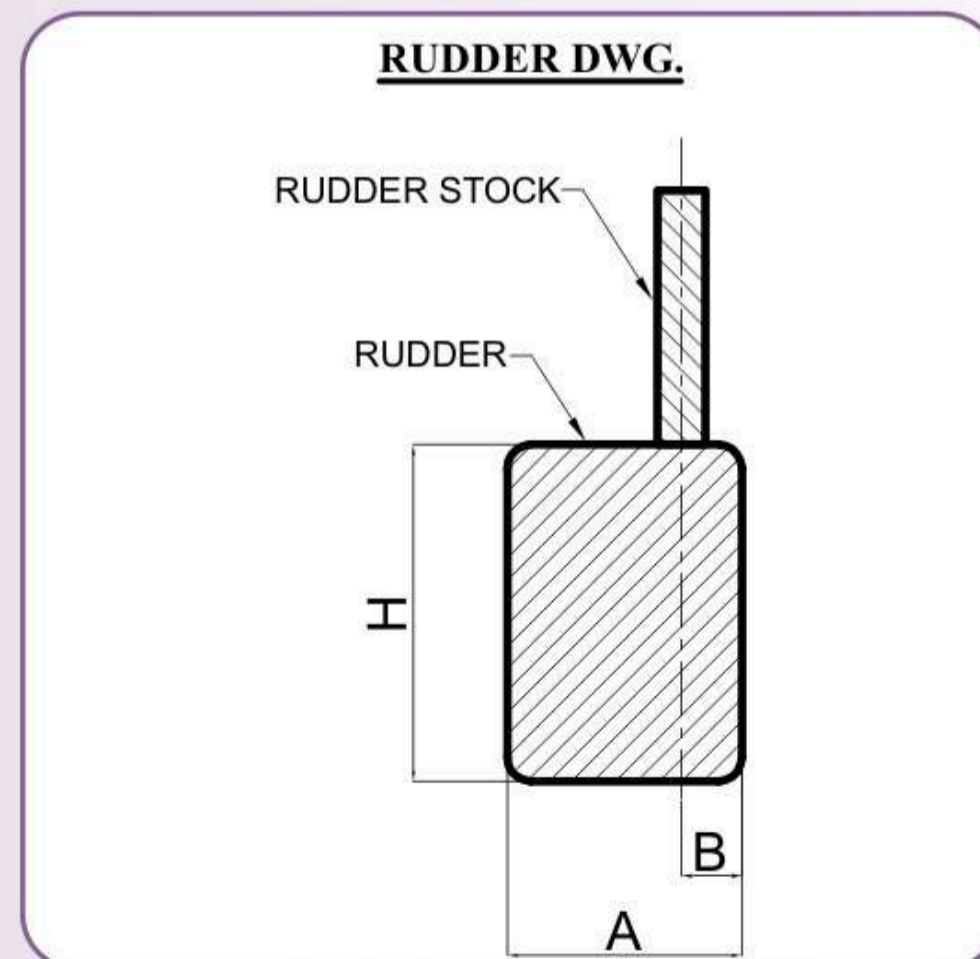

NOTES : 1. Please fill in this data sheet with your Vessel data, and email to info@macnhomsystems.com OR Whatsapp to +91 90729 00576.
 2. All dimensions are in mm.
 3. Dimensions are reference purpose only; kindly confirm with our Technical Department.