

Let's make sailing safer

At Mac N Hom Marine Equipments (P) Ltd., we are focused on range of products that meet the ever increasing demands of Marine based customers in terms of sophistication and diversification. We have brought to market innovative products, one after another to provide only the highest quality goods and services for your requirements and offer customised solutions and challenging applications quickly and cost effectively.

MAC•N•HOM
MARINE EQUIPMENTS (P) LTD.
 Let's make sailing safer



HYDRAULIC STEERING SYSTEMS

Model : JumboZ-1500
IRS Type Approved

Type : Twin Actuators

Ram Dia: 45 x 2

Stroke : 440 mm

Torque: 1778 Kg.m for a Tiller Arm having radius 300 mm



- Tugs & Bollard Pullers
- Medium Barges
- Heavy duty Purse-seins Trawler
- Fishing Vessels

AL SHARQIYAH-2,0man



MV LGT NAVYA BARGE – 2 Nos.
 Konkan Barge Builders Pvt. Ltd., Mumbai



2250 T Coal / Ore Carrier - 5 Nos.
 Shreeji Shipping, Jamnagar



- ☉ Torque rating up to 1778kg.m
- ☉ Tiller Arm turn up to 45 degrees on both sides
- ☉ Used in catamaran , single rudder vessels cargo barges/water barges & deep sea vessels
- ☉ Heavy Duty Ram Size : 45 x 2nos

Package Included

1. JumboZ-1500- E (Electro-Hydraulic) :

- Joystick Control Panel
- Relay panel
- Powerpack panel
- Junction box
- Hydraulic Power pack & Sensors
- Emergency Manual-Hydraulic Steering
- Marine coated Ferruled Tubes & Hoses
- Hydraulic Actuator – **JumboZ-1500**

2. JumboZ-1500 ED (Engine Driven):

- Jacketed Hydraulic Power pack with sea water cooling provision
- Steering Wheel - Wooden (27") /SS (24")
- Helm Pump, Steering Column & Self priming unit
- Marine Painted Ferruled Seamless steel Tubes & Hoses
- Emergency Manual-Hydraulic Steering
- Hydraulic Actuator – **JumboZ-1500**



- 1 Joystick Operated Control Panel with audio visual alarms
- 2 Electro Hydraulic Power Pack with Sensors for Electro Hydraulic Package
- 3 Marine Paint Coated, Ferruled Nut ends Seamless Steel Tubes for Smooth Oil Flow
- 4 Emergency Manual Hydraulic version with Helm Pump, Steering Wheel & Self Priming Unit

MAC•N•HOM MARINE EQUIPMENTS (P) LTD.
 57/187-C, 'VRINDAVAN', Chilavannur Road, Kadavanthra, Kochi-682 020, Kerala, India
 Mob.: + 91 9072900576, +91 484 2312396, 2319998,
 E-mail: info@macnhomsystems.com web site: www.macnhomsystems.com
 CIN: U29308KL2018PTC055182



SPECIFICATIONS

- | | |
|---|--------------|
| • Actuator Ram Diameter | : 45 mm. x 2 |
| • Actuator Stroke | : 440 mm. |
| • Force @ 70 Kg / cm ² Hydraulic Pressure | : 5930 Kgf. |
| • Torque with 300 mm. Tiller Arm upto ±45° turn from Midship.
(Actuator Pin to Rudder Shaft Centre distance : 300 mm.) | : 1778 Kgm. |

MOUNTING ARRANGEMENT OF HYD. ACTUATOR **JumboZ-1500 - IRS**

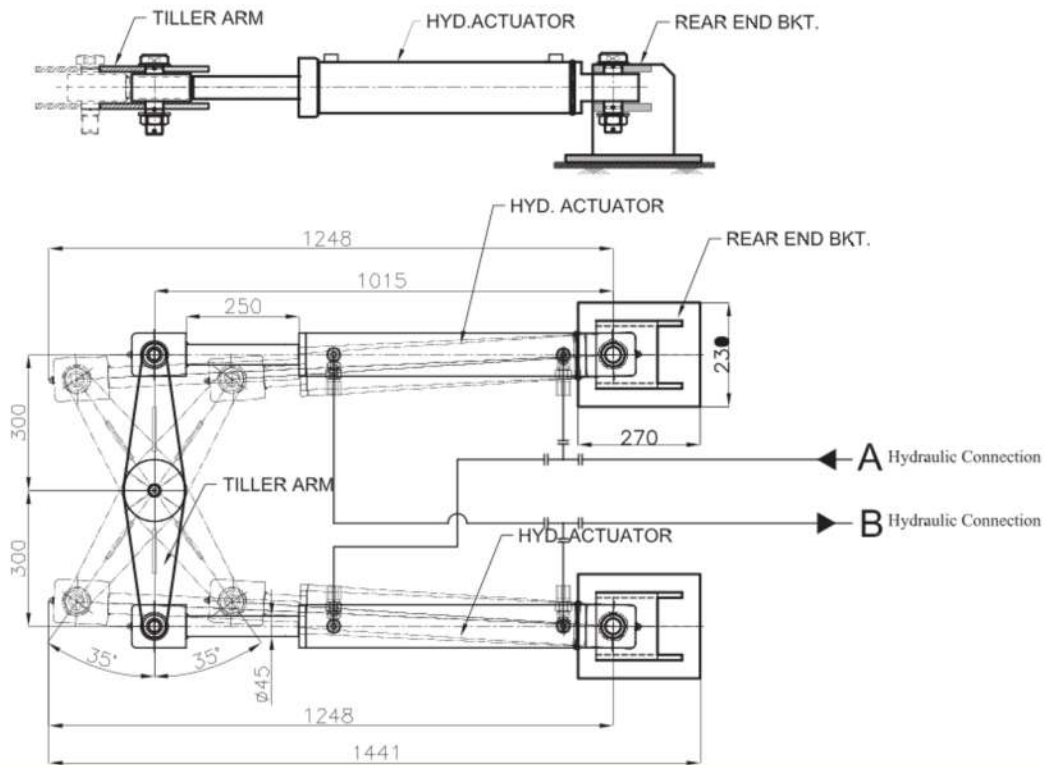

DATA FOR STEERING SELECTION

VESSEL DETAILS		
Length of the Vessel		Meters
Breadth of Vessel		Meters
Draft of the Vessel		Meters
Hull form (Mono / Catamaran)		
No of Engines		Nos
Power of each Engine		HP
Speed of Vessel		Knots
RUDDER DETAILS (See Rudder Dwg.)		
Breadth of Rudder A		Meters
Breadth of Semi-balanced Area B		Meters
Height of Rudder H		Meters
Number of Rudders		Nos
Vessel Regn. Class - No Class / IRS / RINA / DNV / BV		

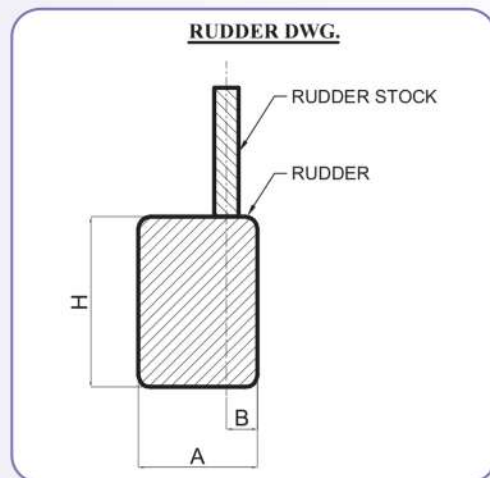

NOTES : 1. Please fill in this data sheet with your Vessel data, and email to info@macnhomsystems.com OR Whatsapp to +91 90729 00576.
 2. All dimensions are in mm.
 3. Dimensions are reference purpose only; kindly confirm with our Technical Department.