

Let's make sailing safer

At Mac N Hom Marine Equipments (P) Ltd., we are focused on range of products that meet the ever increasing demands of Marine based customers in terms of sophistication and diversification. We have brought to market innovative products, one after another to provide only the highest quality goods and services for your requirements and offer customised solutions and challenging applications quickly and cost effectively.

MAC·N·HOM
MARINE EQUIPMENTS (P) LTD.
 Let's make sailing safer



HYDRAULIC STEERING SYSTEMS

Model : JumboZ-2800
 IRS Type Approved

Model Type : Semi-Balanced Actuator (IRS Type Approved)
 Ram Dia : 50 mm x2
 Stroke : 440 mm
 Torque : 2857 Kg.m for a Tiller Arm having radius 300 mm



For Heavy Cargo Barges
Heavy Duty Fire Floats

Fire Boats,
 Khulna Shipyard (Bangladesh Navy)



- ✦ Torque rating up to 700kg.m
- ✦ Tiller Arm turn up to 45 degrees on both sides
- ✦ Used in Catamaran & Single Rudder vessels
- ✦ Used in Cargo Barges/Water Barges & Deep sea Ambulances
- ✦ Heavy Duty Ram Size: 40mm x 2 nos



Cargo Barge
 Sri Maharshi Shipping Pvt. Ltd., Kolkata



Package Included

Electro-Hydraulic Package Includes:

- ✦ Joystick Control Panel with Audio Visual Alarms
- ✦ Hydraulic Power pack & Sensors
- ✦ Emergency Manual-Hydraulic Steering
- ✦ Marine Painted Ferruled seamless steel Tubes & Hoses
- ✦ Hydraulic Actuator - **JumboZ-2800**



Manual-Hydraulic Package Includes:

- ✦ Steering Wheel - Wooden/SS
- ✦ Helm Pump & Steering Column
- ✦ Marine Painted Ferruled Seamless steel Tubes & Hoses
- ✦ Hydraulic Actuator-**JumboZ-2800**



- 1 Joystick Operated Control Panel with audio visual alarms
- 2 Electro Hydraulic Power Pack with Sensors for Electro Hydraulic Package
- 3 Marine Paint Coated, Ferruled Nut ends Seamless Steel Tubes for Smooth Oil Flow.
- 4 Emergency Manual Hydraulic version with Helm Pump, Steering Wheel & Self Priming Unit.



SPECIFICATIONS

- Actuator Ram Diameter : 50 mm. x 2
- Actuator Stroke : 440 mm.
- Force @ 70 Kg / cm² Hydraulic Pressure : 9618 Kgf.
- Torque with 300 mm. Tiller Arm upto ±45° turn from Midship.
(Actuator Pin to Rudder Shaft Centre distance : 300 mm.) : 2857 Kgm.

MOUNTING ARRANGEMENT OF HYD. ACTUATOR **JumboZ-2800 - IRS**

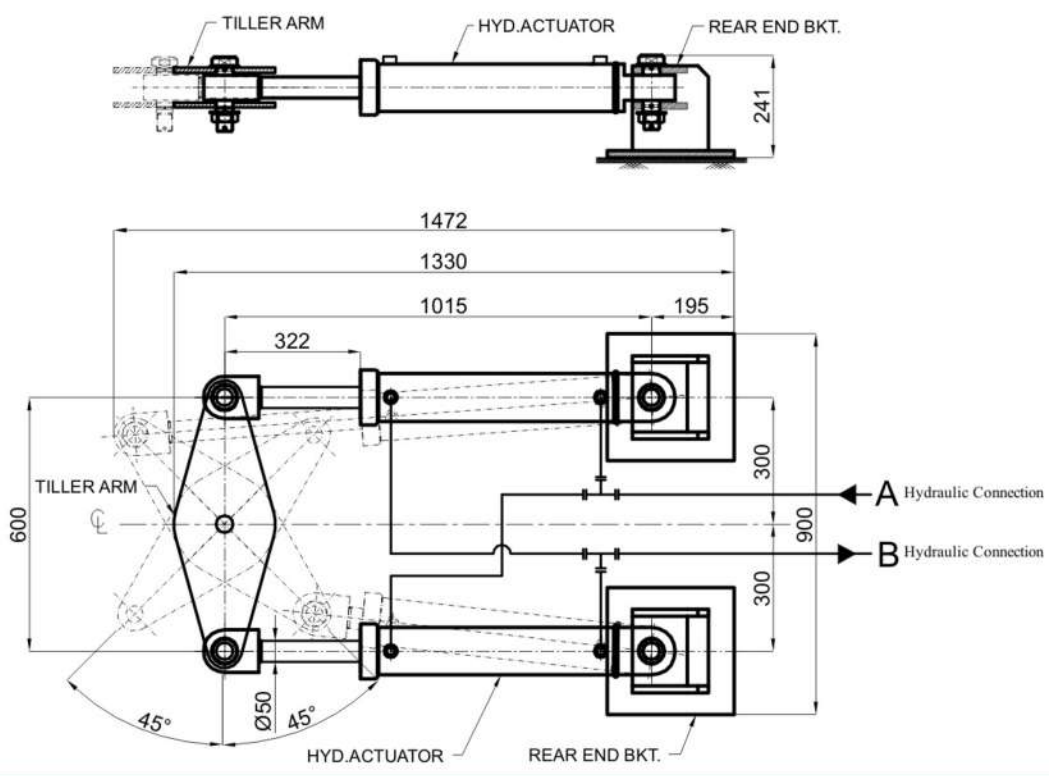

DATA FOR STEERING SELECTION

VESSEL DETAILS		
Length of the Vessel		Meters
Breadth of Vessel		Meters
Draft of the Vessel		Meters
Hull form (Mono / Catamaran)		
No of Engines		Nos
Power of each Engine		HP
Speed of Vessel		Knots
RUDDER DETAILS (See Rudder Dwg.)		
Breadth of Rudder A		Meters
Breadth of Semi-balanced Area B		Meters
Height of Rudder H		Meters
Number of Rudders		Nos
Vessel Regn. Class - No Class / IRS / RINA / DNV / BV		

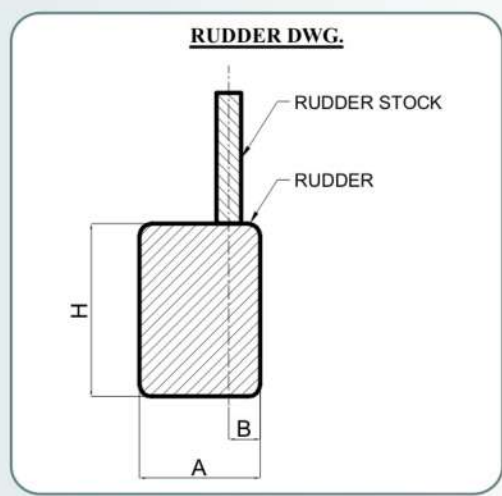

NOTES : 1. Please fill in this data sheet with your Vessel data, and email to info@macnhomsystems.com OR Whatsapp to +91 90729 00576.
 2. All dimensions are in mm.
 3. Dimensions are reference purpose only; kindly confirm with our Technical Department.